

T-10275

Fig. A

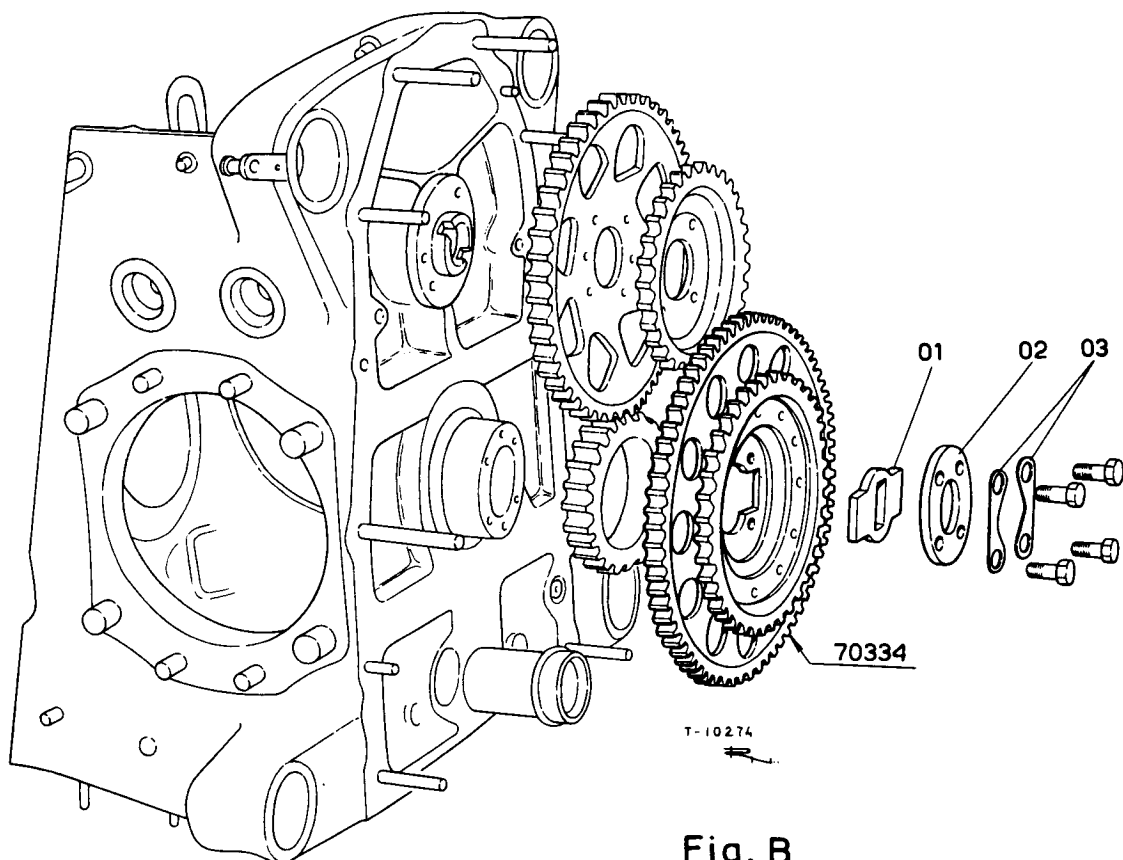

T-10274

Fig. B